



BSSK1000 & BSSK1001

Wireless Ultrasonic Parking Sensor Systems for Commercial Vehicles



BSSK1000:
Under Mount Backup Sensor System



BSSK1001:
Flush Mount Backup Sensor System

INSTALLATION / USER'S MANUAL

CONTENTS

- How To Read Display..... 3
- Sensor Detection Range & Warning Method 4
- Sensor Installation.....5
- Control Box Installation..... 6
- Wiring Diagram..... 7
- Display Installation.....7
- Testing & Maintenance.....8

WIRELESS BACKUP SENSOR KIT WITH ULTRASONIC TECHNOLOGY

Rosco ultrasonic wireless backup sensor systems provide safety advantages that protect drivers, vehicles and business profits. These systems are ideal for school buses, work trucks, RVs and other commercial vehicles. The wireless backup sensor system is automatically activated when the driver shifts into reverse gear. Small flush or surface mount sensors are installed at the rear of the vehicle. The sensors send and receive ultrasonic waves that reflect off obstructions and alert the driver to their presence. There is an audible alarm that gradually increases in frequency as you approach the obstacle, and an LCD screen displays the distance to the obstruction. A continuous "beep" and red distance indicator alerts the driver when the vehicle is within one (1) foot of the obstruction.

Technical Specifications:

Operating range:	DC9 ~ 32V
Operating current:	20-150mA @ 12V
Detection distance:	8.0 ~ 0.0 ft
Ultrasonic frequency:	40KHz
Working temperature:	-22 ~ 158°F
Display size:	3.7 x 1.9 x 0.8 inches
Sensing resolution	0.5 ft

Installation Tools:

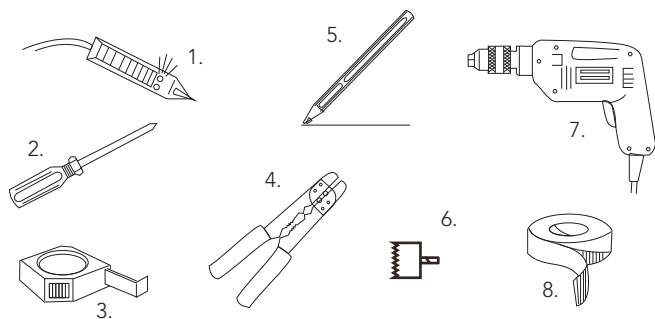

- 1. Wire Tester
- 4. Wire Stripper
- 7. Drill
- 2. Phillips Screwdriver
- 5. Pencil
- 8. Tape
- 3. Tape Measure
- 6. Hole Saw

BSSK1000 UNDER MOUNT BACKUP SENSOR SYSTEM COMPONENT LIST:

Components:	P/N	Qty.
LED Display w/Double Sided Tape	BSSKD200	1
Control Box	BSSKT300	1
Under Mount Sensors (Set of 4) w/Hardware Kit	BSSKS100	1
Hardware Kit Group 1: Foam Wedges		8
Hardware Kit Group 2: Screws and Washers		12
Hardware Kit Group 3: Tie Wraps		15

BSSK1001 FLUSH MOUNT BACKUP SENSOR SYSTEM COMPONENT LIST:

Components:	P/N	Qty.
LED Display w/Double Sided Tape	BSSKD200	1
Control Box	BSSKT300	1
Flush Mount Sensors (Set of 4) w/Hardware Kit	BSSKS101	1
Hardware Kit Group 1: Washers		8
Hardware Kit Group 2: Screws		4
Hardware Kit Group 3: Tie Wraps		15



WARNING

- Please read this manual carefully before using the product.
- This system is intended as an aid to safe reverse operation. Drivers must always use extreme caution when operating a vehicle
- Sensors are to be used as parking aides for fixed objects such as vehicles and buildings. They are not to be used for pedestrian detection.

HOW TO READ DISPLAY

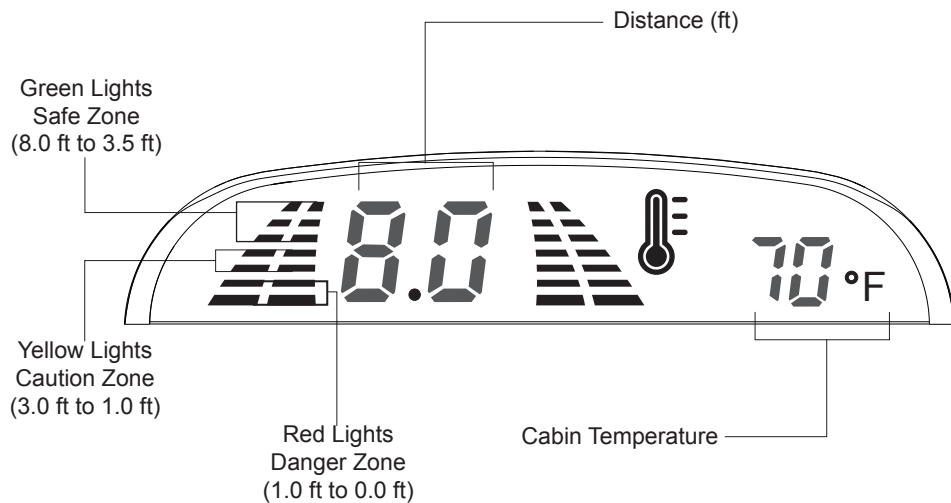

Both the Flush and Under Mount backup sensor systems are automatically activated when the driver shifts into reverse gear.

There are three (3) volume options. They are HIGH, LOW and OFF. The adjustment switch is on the back cover of the display unit.

UNIQUE ID

Each control box has a unique ID to ensure secure data transmission from control box to the display. The display has the capability to pair with a new control box. This allows the customer to replace the display or control box if necessary.

How To Reprogram The Display:

1. Turn ignition on (DO NOT START).
2. Put the car in reverse.
3. Press the button on back of display one time for about 5 seconds. (See Below)
4. Display will store the unique ID of the nearest control box automatically.

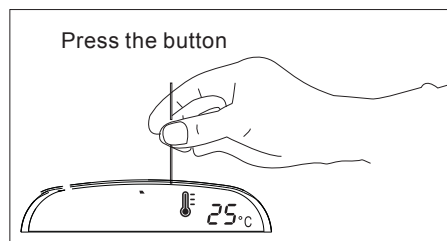

SENSOR DETECTION RANGE & WARNING METHOD

1. Safe Zone

Distance Display:
8.0 to 3.5 ft.

Alarm Sound:
8.0 to 5.5 ft. - None
5.0 to 3.5 ft. - Slow "Beep"

LED Lights:
Green

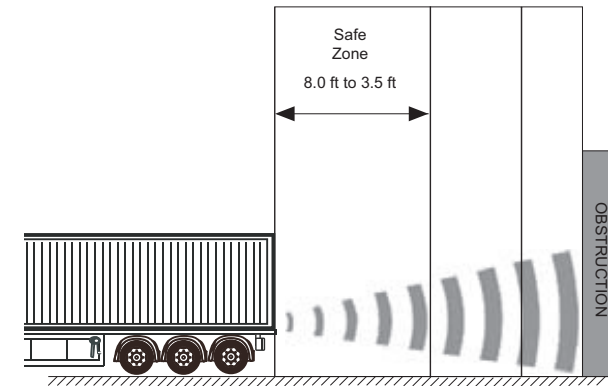

2. Caution Zone

Distance Display:
3.0 to 1.0 ft.

Alarm Sound:
Fast "Beep"

LED Lights:
Yellow

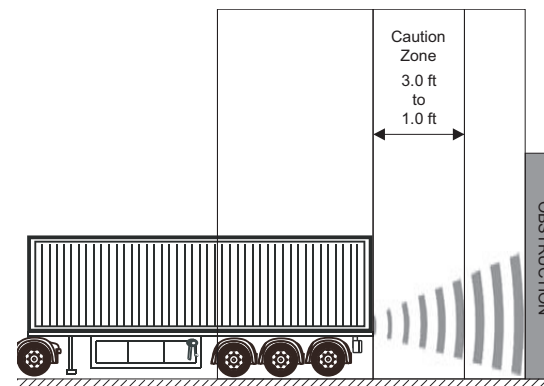

3. Danger Zone

Distance Display:
1.0 to 0.0 ft.

Alarm Sound:
Continuous "Beep"

LED Lights:
Red

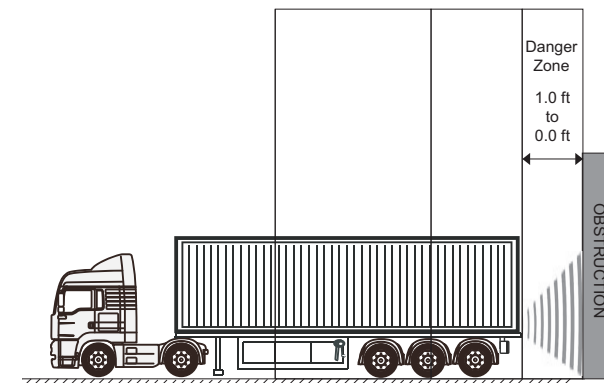

SENSOR INSTALLATION

IMPORTANT:

The sensor installation steps are applicable to BOTH the Flush Mount and Under Mount Backup Sensor Systems.

The individual sensors are labeled A, B, C, and D. The sensors should be installed in the following order:

- Sensor A:** Outer Driver Side
- Sensor B:** Inner Driver Side
- Sensor C:** Inner Passenger Side
- Sensor D:** Outer Passenger Side

It is highly recommended to install all four (4) sensors. The system however, will work with less than four if the vehicle configuration cannot accommodate all the sensors.

1. For all setups, installer MUST make certain that sensors are centered both horizontally and vertically.
2. Installation height for sensors should be between 1 to 4 ft. above ground.
3. Sensors A & D should be located 6 to 9 inches from outer edge of vehicle.
4. When installing sensors, make certain that no part of vehicle (hitch, etc.) is within 90° of the sensing range.
5. When installing sensors be certain the sensor is level, not at a angle. Place provided washers and wedges if necessary.
6. Surface to install sensors must be vertical and flat.

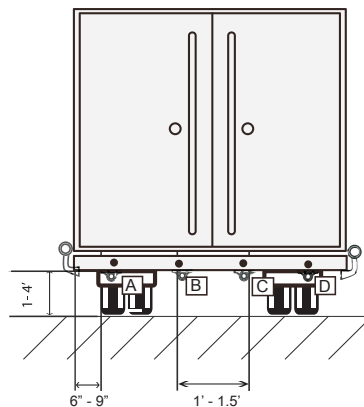

Figure. 1

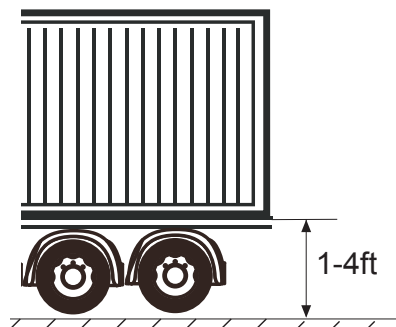

Figure. 2

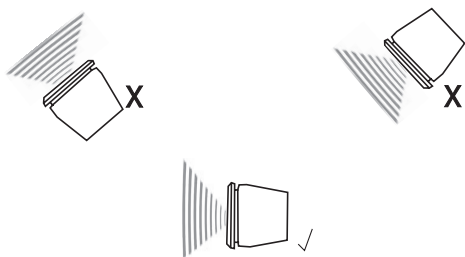

Figure. 3

SENSOR INSTALLATION

IMPORTANT:

The marked sensor cables (A,B,C,D) must be connected to the corresponding marked inputs on the control box. See page 7.

1. Control Box MUST be installed in the cargo area or other protected area.
2. After choosing a suitable control box position in the vehicle, drill the required holes to route the sensor cables to vehicle interior.
3. Pull sensor cables through drilled hole to vehicle interior.
4. Connect sensors cables to the control box.
5. Connect power and ground wires to the reverse light circuit.

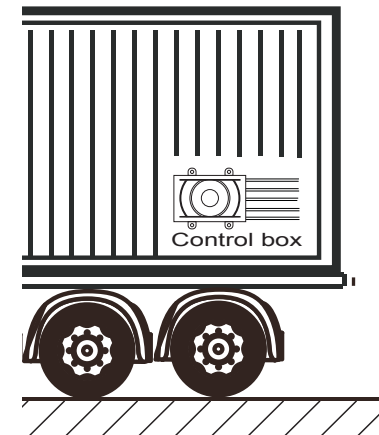

Figure. 1

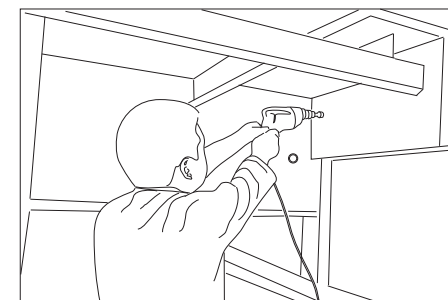

Figure. 2

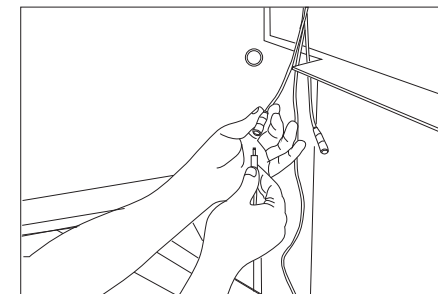
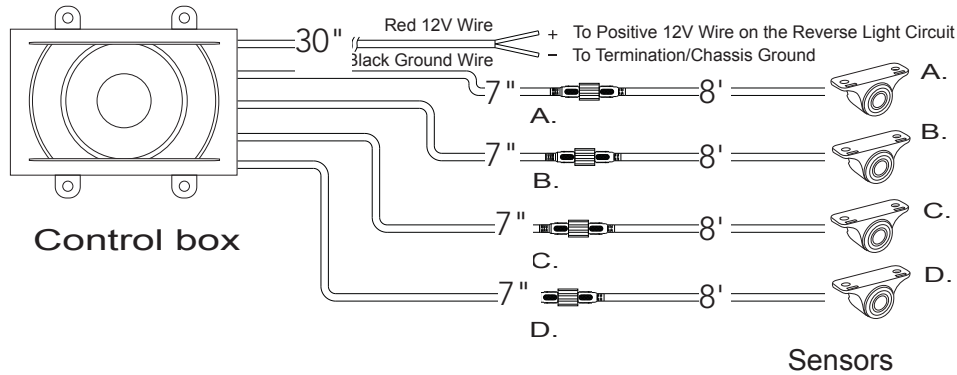

Figure. 3

WIRING DIAGRAM



IMPORTANT: The marked sensor cables (A,B,C,D) must be connected to the matching marked inputs on the control box.

DISPLAY INSTALLATION

1. Select an area easily visible to the driver and mount display firmly. Clean surface with alcohol and use the included double sided tape to mount. (Figure 1)
2. Connect RED wire from display unit to ignition/switch power source.
3. Connect BLACK wire to vehicle ground.
4. Locate optional temperature sensor as desired.
5. Power up and test.

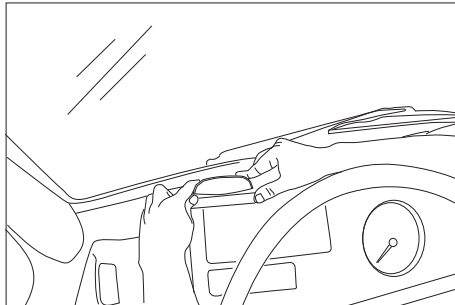

HOW TO TEST

1. Apply the parking brakes.
2. Turn Ignition on (DO NOT START).
3. Place the shift gear to reverse position.
4. From behind the vehicle proceed to check the system by placing an item back and forth in front of each sensor.

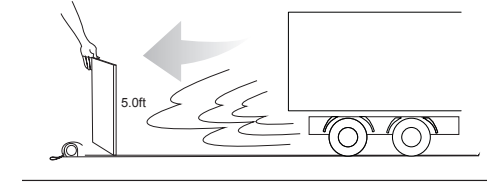

Maintenance:

Always keep sensor clear from dirt, snow, and mud. Clean sensors with a soft towel and low pressure water.

Trouble Shooting:

Problem	Cause	Solution
No power to display.	Bad power connections.	Check power connections.
Display on, but no reading while reversing.	Display not synchronized with control box.	Press button on back of display for five (5) seconds to sync with control box.
Orientation of sensors do not match.	Sensor cables installed to wrong control box ports.	Check and change the sensor cables to correct ports on control box.
System always detects the same distance.	Sensor may be detecting ground or debris (mud, snow, etc).	Check and adjust the vertical angle on the sensor. Clean sensor of any debris.

NOTES

NOTES



A CENTURY OF AUTOMOTIVE VISION SAFETY

90-21 144th Place, Jamaica, New York 11435

TEL (800) 227-2095 • FAX (718) 297-0323

techsupport@roscovision.com www.roscovision.com

RoHS **FC**

Lit. P/N: MO071615